



KERNLOCHBOHRER[®]
PROFESSIONAL POWER TOOLS



Operating instructions

DKB-200/3SH

Kernlochbohrer GmbH
Geigersbühlweg 52
72663 Großbettlingen
Tel. 07022-5034900
Email: info@kernlochbohrer.com

Version 0 6. Output 05/2023

Content

Introduction and description	3
About this guide	3
Thanks to the buyer	4
Explanation of symbols	4
Safety regulations	4
Product structure	8
Technical data	9
Use and care	9
Precautions	10
Preparation	10
Operation on drill rig	11
Mounting and assembly of core drill rig and standsr	11
Changing drill bits	11
Drill and machine cooling	12
Electrical connection	13
Water supply connection	14
Gear change	14
Drilling	15
Electronic overload protection	16
Mechanical overload protection	17
Shutdown carbons	17
Segment break	17
After drilling	18
Daily maintenance of the power tool	19
Behavior in the event of malfunctions	20
Troubleshooting	21
Environmental protection	22
Noise / Vibration	22
Warranty	23
Exploded view	24
EC Declaration of Conformity	27

Introduction and description

The core drilling equipment of the DKB series is intended for professional use and may only be operated by instructed persons. Strictly adhere to the instructions in the operating manual to avoid electric shock or fire.

Our company declines all responsibility in the event of violations of the operating instructions that may result in injury or machine damage. In addition, all currently applicable regulations of the Accident Prevention Regulations (UVV) and the Employer's Liability Insurance Association (BG) must be observed.

In conjunction with the appropriate drill bits, the machine is intended for drilling concrete, stone and masonry in wet and dry cutting. However, care must be taken to ensure that you select the correct drill bit for the corresponding drilling technique in each case.

The machine may only be serviced by persons who have the appropriate qualification and certification.

About this guide

These operating instructions are for the models
DKB-200/3SH

Check the machine model against the nameplate.



Thanks to the buyer

Thank you for purchasing a core drill of the DKB series from Kernlochbohrer GmbH. Please read the operating instructions carefully and observe the safety instructions. Through proper operation, you will fully appreciate the outstanding performance of our products. Keep this manual in a safe place for future reference.

If you have any questions regarding the operation of the core drill, please contact the company Kernlochbohrer GmbH directly. We are available to answer your questions at any time.

Note:

Kernlochbohrer GmbH reserves the right to change the design and appearance of the products and their operating instructions. Future changes to the operating instructions will be made without prior notice.

Explanation of symbols



General Danger Warning. Failure to follow these safety precautions and instructions may result in electric shock, fire and/or serious injury.

Safety regulations

- ❖ Read all precautions before start-up and keep the operating instructions. In addition, all currently applicable regulations of the Accident Prevention Regulations (UVV) and the Employer's Liability Insurance Association (BG) must be observed.
- ❖ Please follow the operating instructions carefully, as failure to follow these safety precautions and instructions may cause electric shock, fire and/or serious injury.

1. Keep your work area clean and well lit. Disorder or unlit work areas can lead to accidents.
2. Do not work with the power tool near flammable liquids, gases or dust. Power tools produce sparks that can ignite dust or fumes, causing explosions.
3. Keep children and other persons away while using the power tool. If you are distracted, you may lose control of the tool.
4. Be attentive, work with concentration and pay attention to what you are doing. Do not use a power tool when you are tired or under the influence of drugs, alcohol or medication. A moment of inattention can result in serious injury.
5. Wear suitable protective equipment and always protective goggles. Wearing suitable protective equipment such as a dust mask, non-slip safety shoes, hard hat or hearing protection reduces the risk of injury.



6. Avoid unintentional starting of the machine. Make sure that the power tool is switched off before connecting it to the power supply. If you have your finger on the switch when carrying the power tool or connect the machine to the power supply when it is switched on, this can lead to accidents.
7. Remove setting tools or wrenches before switching on the power tool. A tool or wrench that is on a rotating device can cause injury.
8. Avoid unusual postures. Ensure a secure footing and maintain your balance at all times. Do not work on a ladder. This will give you better control of the power tool in unexpected situations.

9. Wear appropriate clothing. Do not wear loose clothing or jewelry. Keep hair, clothing and gloves away from moving parts. Loose clothing, jewelry or long hair can be caught by moving parts.
10. Do not overload the device. Use the appropriate power tool for your work. With the appropriate power tool, you will work better and more gently in the specified power range.
11. Do not use a power tool whose switch is damaged. A power tool that cannot be switched on and off is dangerous and must be repaired.
12. Unplug the power tool from the wall outlet before making any adjustments, replacing accessories, or setting aside the power tool. This safety measure prevents the power tool from starting unintentionally.
13. Keep unused power tools out of reach of children. Do not allow persons to use the device who are not familiar with it or have not read these instructions. Power tools are dangerous when used by inexperienced persons.
14. Note that the voltage must not exceed +/-5% of the nominal voltage. Higher voltages can cause irreparable damage. Note that higher voltage peaks are not generated when operating the machine via a generator.
15. The plug of the power tool must match the socket. Do not change the plug under any circumstances. Do not use adapter plugs with grounding-type forces. Unmodified plugs and matching outlets reduce the risk of electric shock.
16. Avoid body contact with grounded surfaces or grounded components such as pipes, radiators, ranges, and refrigerators.
17. Do not expose power tools to rain or wet conditions. Water entering a power tool increases the risk of electric shock.

18. Never use the cord to carry or pull the power tool or to unplug the power tool from the wall outlet. Keep it away from heat, oil, sharp edges or moving parts. Damaged, crushed or twisted cables increase the risk of electric shock.
19. When using a power tool outdoors, use only an extension cord that is suitable for outdoor use. Using a cord that is suitable for outdoor use reduces the risk of electric shock. When using with an extension cord, also make sure that the extension cord has the same cross-section as the cord on the machine.
20. The use of products such as cutters, grinders, drills that machine sand or other materials can generate dust and fumes that may contain hazardous chemicals. Check the type of material you are going to machine and use a suitable respirator.
21. Non-approved spare parts and any modification are prohibited on our products.
22. If the operation of a power tool in a damp environment is unavoidable, use a residual current circuit breaker. The use of a ground fault circuit interrupter reduces the risk of electric shock.
23. If a vacuum cleaner and suction device are required, make sure they are connected and used properly. The use of a vacuum cleaner can reduce dust-related hazards.

Product structure

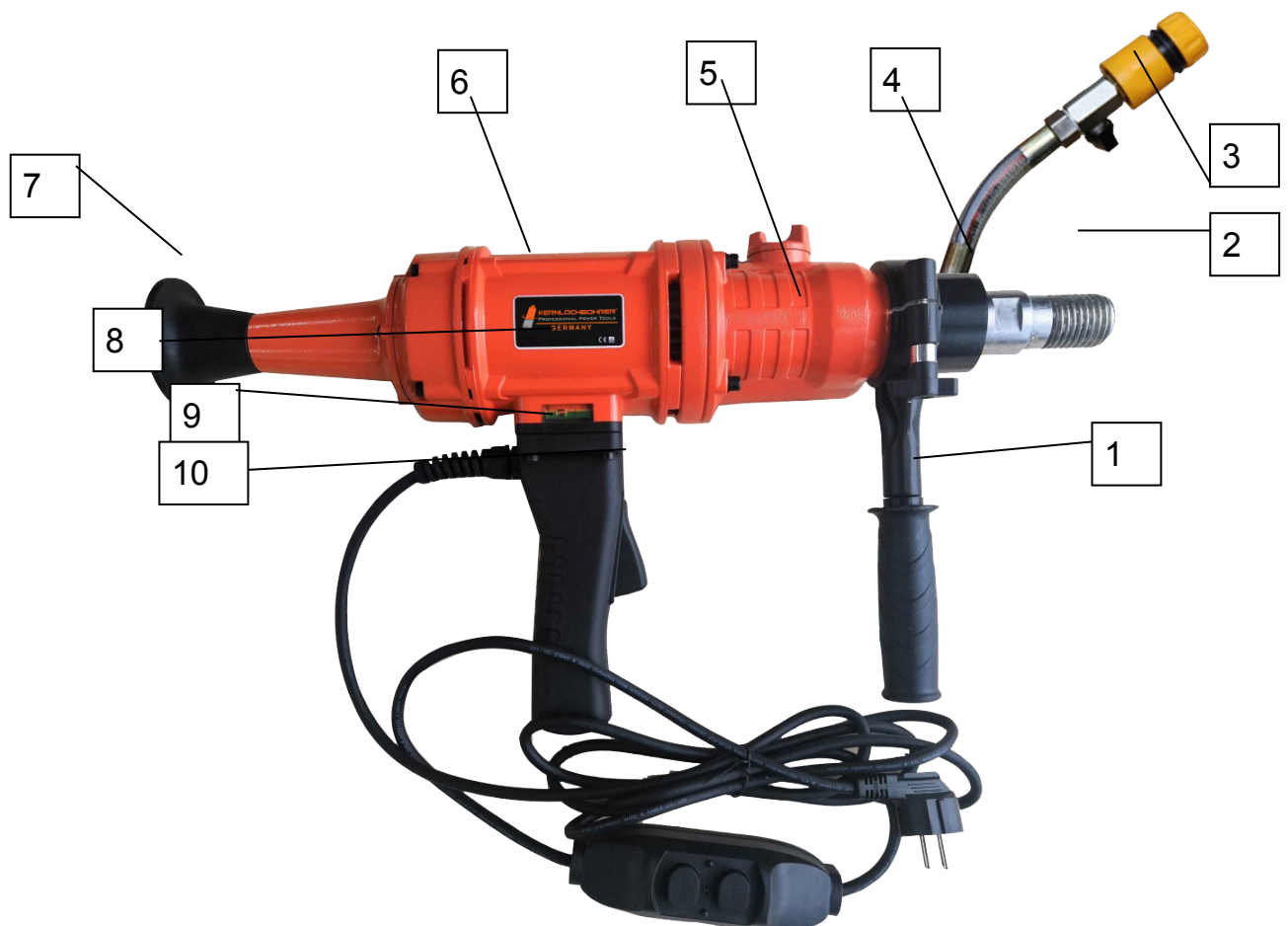

- | | | | |
|----|-------------------------------------------------------------|-----|----------------------------------|
| 1. | Guide handle | 5. | 3 speed oil bath gearbox |
| 2. | Tool holder
1 ¼" UNC (male thread)
½" (female thread) | 6. | Motor housing |
| 3. | Water connection | 7. | Shoulder support |
| 4. | Oil seal | 8. | Soft start / overload protection |
| | | 9. | Main handle |
| | | 10. | Start switch |

Technical data

Model	DKB-200/3SH
Art no.	1897
Power	2100W
Voltage	230V
Weight	6kg
Frequency	50-60HZ
Max. Drilling diameter brick	200mm
Max. Drilling diameter concrete without stand	150mm
Max. Drilling diameter concrete with stand	180mm
Speed	100-590/1310/2730 1/min
Spindle thread	1 ¼" UNC
Compatible stands	KBS-200/M, 60mm Clamp holder KBS-280/M, 60mm Clamp holder

In order to constantly improve the product, our company reserves the right to change the technical data without prior notice.

Use and care

Only use diamond core bits which are in a sharp and undamaged condition. Properly maintained diamond core bits with sharp cutting segments do not become entangled so quickly and are easier to guide.

Use the power tool, accessories and drill bits etc. in accordance with these operating instructions, taking into account the working conditions and the work to be performed. Using the power tool for operations other than its intended use could result in a hazardous situation.

Have your power tool repaired only by qualified personnel and only with original spare parts.

Precautions

1. ALWAYS wear hearing protection! When using drilling motors, the loud drilling noise in the working area can cause hearing damage.
2. When drilling, keep a sufficient distance to the core drill and do not touch any rotating parts. Protect the danger zone and keep children and other persons away from it. Falling and splashing parts can cause injuries.
3. This diamond core drill is intended for professional use only and may only be operated by trained personnel. The appropriate use of the core drill includes drilling rock, reinforced concrete and masonry.
4. The drill motor must be checked regularly (approx. every 6 months) by a certified electrician in accordance with VDE.
5. When used for overhead drilling, a functional water collection ring must be used. Make sure that no water can get into the motor.
6. Switch off the core drill immediately if it stops for any reason. After you have determined and eliminated the cause and performed a visual inspection of the device and core bit, the core drill can be restarted.

Preparation

Subject the core drill to a brief visual inspection before each start. Also check whether the network voltage corresponds to the voltage specified on the nameplate of the tool.

Operation on drill rig

All drilling machines of the DKB/H series are designed for use with a drill stand. Only place the machine in a stable drill stand equipped with precise guides. Make sure that the machine axis is parallel to the drill stand column. Only use drill stands with sufficient stability.

Mounting and assembly of core drill rig and stand

Make sure that the core drill is not attached to the drill stand before mounting the drill stand in the desired position.

The DKB-200/3SH core drill can be operated in manual mode or also with a core drill stand. When mounting, a \varnothing 60mm clamp holder must be used

Please observe the operating instructions of the core drill rig used.

Should you use our vacuum base plate VGP-420/PRO for mounting the core drill stand, make sure that the vacuum is at least -0.9bar and also make sure that the seal is not worn or damaged.

Changing drill bits

A diamond core bit is a cylinder which is equipped with brazed or laser welded segments. There are 2 types of diamond core bits, wet drill bits and dry drill bits. These usually have a 1 1/4UNC or an M16 female threaded connection. Our DKB-H series core drills can perform both wet and dry drilling. The drive spindle has a 1 1/4" UNC male thread and a 1/2" female thread.

For easier removal of the core bit, you can apply waterproof grease to the spindle thread of the machine.

To mount a drill bit on the core drill, simply screw it onto the drill spindle. With the aid of a copper ring (not included in the accessories), you can loosen the drill bit more easily.

Make sure that you have disconnected the mains plug from the mains before changing drill bits or removing them.

The core drill and the drill bit are relatively heavy. For this reason, always wear protective gloves to prevent injuries to your hand from the sharp tool.

For the DKB-200/3SH core drill, use an open-end wrench with SW32 for loosening. Never loosen the core bit with (hammer) blows, as this will damage the core drill.

After mounting the drill on the machine, run it briefly and check the radial runout of the core bit.

Drill and machine cooling

The gearbox of the drill motor has splash lubrication for cooling.

The diamond segments of the wet core bit are cooled with water.

The electric motor is air-cooled.

Electrical connection

To reduce the risk of electric shock and to protect the operator, the DKB-200/3SH core drill rig must only be operated via a Portable Residual Current Device, or PRCD personal circuit breaker.

After connecting to the power supply, first press the "RESET" button on the PRCD circuit breaker to energize the circuit to the core drill. In the event of a voltage drop, the PRCD circuit breaker switches off and must be switched on again as soon as the power supply is restored. The fault current at which the PRCD circuit breaker switches off is 10mA.



Never place or put the PRCD breaker in water. Before starting work, check for proper operation by pressing the TEST button on the PRCD circuit breaker. Never operate the core drill directly from the mains power source without a PRCD circuit breaker.

Before commissioning, check that the mains voltage and frequency match the data given on the type plate. Use only 3-core extension cable with protective conductor and sufficient cross-section (min. 2.5mm²). Too weak a cross-section can lead to excessive power loss and overheating of the machine and cable. The machine is equipped with a start-up current limiter, which prevents the automatic safety device from being triggered unintentionally.

Water supply connection

If the core bit is not cooled sufficiently with water, the diamond segments may heat up, which will damage them and considerably reduce the service life of the core bit. Therefore, you should always make sure that a steady water supply is ensured.

To connect the water supply, attach the quick coupling to a water hose. Use clean water. Using water that is contaminated will accelerate the process of water seal wear.

The maximum water pressure must not exceed 3 bar.

The water serves as a coolant to prevent the drill from heating up excessively during drilling.

Dust and particles formed during drilling can clog the water supply system. If necessary, this must be checked and cleaned.

Never allow water to enter the motor. It could lead to an electric shock.

Gear change

The DKB-200/3SH core drill has a mechanical 3-speed gearbox. Adjust the speed of the machine to the drill diameter.

Turn the gear switch to the faster or slower gear until it engages. The speed change is to be carried out only when the machine is at a standstill; if necessary, support the switching process by slightly turning the work spindle. If the machine stalls due to the hardness of the material, select a lower gear to protect the machine from overload.

If the spindle does not rotate or noises occur after starting, the gear may not be engaged properly. Stop the machine immediately and adjust the gear accordingly until it engages. Simultaneously turn the spindle back and forth until it is engaged. Never shift the machine to another gear during operation.



WARNING!

- **Only shift the gear unit when it is at a standstill!**
- **Never use force to switch over!**
- **Do not use tools such as pliers or hammers to switch over!**

Drilling

Always switch on the machine without load.

After switching on, next open the water line valve.

When water flows out of the center of the drill, you can carefully start drilling.

If you are operating the core drill without a drill stand, begin the gate cut by not approaching the drill diameter with the full cutting face of the drill. Once a V-notch cut is drilled on the drill face, line up the drill at a right angle while increasing the feed pressure.

Increase the feed pressure once the depth of cut reaches approximately 10mm.

Always keep an eye on the condition of the drill motor. If you notice that it starts to smoke slightly or you notice the smell of an electric motor, relieve the core drill by withdrawing it from the core hole. Then continue drilling slowly and carefully. In this way, you prevent the carbon brushes from burning off due to a prolonged overload of the electric motor.

When you have almost reached the end of the through hole, please reduce the feed pressure at this point until the drill bit exits at the other side.

There are vertical and horizontal bores as well as angle bores. For angle drilling, use the angle adjustment function of the drill stand.

If you have selected too high a speed during drilling or you are working with too high a feed pressure, this can cause the drill bit to jam.

If, during the drilling process, you notice that the feed rate decreases while the force remains the same and the water coming out of the drill hole is clear and has some metal splinters, you have encountered rebar. Reduce the pressure on the drill bit to cut through this easily. You can increase the pressure again when you have cut through the reinforcing iron.

If wooden beams, thick asphalt or bitumen are cut, this will increase the current. In this case, reduce the feed rate to continue drilling.

If you need to drill deeper than the usable length of your drill allows, an optional extension can be used. Initially, drill only as far as the usable length of the crown allows. Remove the crown and loosen the drill core from the hole without moving the core drill unit. Now screw the required extension between the core bit and the core drill unit to the drill spindle. Now attach the core bit to the extension. Push the crown back into the drill hole.

Note:

A copper ring can facilitate the loosening of the diamond core bit and extension. (Not included in the scope of delivery.)

Electronic overload protection

The DKB-200/3SH is equipped with an electronic overload protection. If the core drill is in an overload state for a long time, the machine switches off for its own protection. Disconnect the device from the power supply. Carry out a visual inspection of the device.

Mechanical overload protection

This machine is equipped with a mechanical slip clutch to protect the operator and the machine from excessive torque forces. If the drill suddenly jams in the hole, the safety clutch disengages and the drill spindle stops.

Make sure that the load on the clutch does not exceed max. 3-4 seconds. Unload the machine immediately. Otherwise, the high wear may destroy the safety coupling. Do not continue drilling if the slipping clutch has been triggered, reduce the feed rate immediately and wait until the drill bit has reached the desired speed again.



Caution!

A worn clutch must be replaced immediately by a specialist at an authorized workshop. Working with a worn slipping clutch can lead to serious injuries.

Shutdown carbons

The power tool is equipped with a self-shutting carbon brush to protect the motor. If the carbon brushes are worn out, the machine switches off automatically. In this case, both carbon brushes must be replaced at the same time by original carbon brushes from our store by a trained electrician according to VDE.

Segment break

If a diamond segment, part of the reinforcement or similar comes loose during drilling, causing the drill bit to jam, stop work on that hole and drill a hole with the same center and a 15-20mm larger diameter.

Note:

Do not try to finish drilling with another core bit of the same diameter!

After drilling

When the drilling process is completed:

1. Pull the drill bit out of the hole.
2. Switch off the motor. Use the motor switch for this purpose and not the PRCD circuit breaker.
3. Close the water supply.

Remove the drill core if it remains in the drill bit:

1. Disconnect the core bit from the core drill (if possible).
2. Set the drill bit vertically.
3. Tap lightly against the core barrel with a wooden hammer handle or a rubber mallet until the core slips out. Never hit the core bit with force against a wall or similar or hit it with tools such as a hammer or open-end wrenches, as otherwise the core barrel may become distorted and neither the drill core can be removed nor the core bit can be reused.

Remove drill core for a blind hole

Break off the core with a wedge or lever. Lift out the core with suitable pliers or drill a hole in the core. Screw an eyebolt into it with the aid of a suitable dowel and pull the drill core out on it.

Daily maintenance of the power tool

Before starting maintenance or repair work, be sure to disconnect the power plug!

Repairs may only be carried out by qualified personnel who are suitable on the basis of their training and experience. The unit must be checked by a trained electrician according to VDE after each repair. The power tool is designed to require a minimum of care and maintenance. However, the following points must always be observed:

1. Check that all screws and nuts are well tightened.
2. Check that the water seals are intact.
4. Check if the PRCD circuit breaker is working properly.
5. Always keep all accessories and the machine clean and dry.
6. The DKB-200/3SH has an oil bath gearbox. The gear oil must be changed after approx. 6 years. Proceed as follows: Place the machine vertically. Loosen the gearbox housing cover. Remove the generator and the intermediate cover. Change the gear oil. The filling quantity is approx. 230ml. Use only gear oil SAE 85W-140!
A renewal of the gear oil causes a significant increase in the service life of the gear unit.



Caution!

If gear oil leaks, switch off the core drill immediately, otherwise the gearbox may be damaged.

7. After approx. 300 operating hours, the carbon brushes must be checked by a trained electrician according to VDE and replaced if necessary (only use original carbon brushes from our store).

8. If cooling water leaks uncontrollably from the oil seal, have it replaced by a specialist workshop and use only original spare parts from our store for this purpose..
9. After finishing the work, remove the drill bit and then clean the entire machine. Do not forget to lubricate the spindle thread. Keep the power tool out of reach of children and in a dry environment.

Behavior in the event of malfunctions

Switch off the machine in case of malfunctions, disconnect it from the power supply. Work on the electrical system of the machine may only be carried out by a qualified electrician in accordance with VDE.

Troubleshooting

Fehler	Mögliche Ursache	Behebung
Device does not run	<p>Mains power supply interrupted</p> <p>Power cord or plug defective</p> <p>Switch defective</p> <p>PRCD switch switched off</p>	<p>Plug in other electrical device, check function</p> <p>Have it checked by a trained electrician in accordance with VDE and replaced if necessary.</p> <p>Check by a trained electrician according to VDE and have replaced if necessary</p> <p>Switch on PRCD switch (RESET)</p>
Motor running - Drill bit stationary	<p>Gear not engaged correctly or jumped out unintentionally</p> <p>Gear defective</p>	<p>Engage the required gear by actuating the gear switch.</p> <p>Have the unit repaired by a specialist workshop</p>
Motor running - Drill bit stops at low load	Locking screw on the slipping clutch has come loose	Have the slipping clutch readjusted by a specialist workshop
Drilling speed decreases	<p>Drill bit defective</p> <p>Too high water flow prevents self-sharpening of the core bit</p> <p>Drill bit polished</p>	<p>Check the drill bit for damage and replace if necessary.</p> <p>Regulate water quantity</p> <p>Sharpen drill bit on sharpening stone</p>
Motor switches off	<p>Unit comes to a standstill</p> <p>Unit too warm - Motor overload protection has tripped</p> <p>Carbon brushes worn out - Shutdown carbons switch off</p>	<p>Guide the device straight</p> <p>Unload the device and let it start up again by pressing the switch.</p> <p>Have both carbon brushes changed by a trained electrician in accordance with VDE</p>
Water leaks from the gearbox housing	Wellendichtringe defekt	Have the device repaired by a specialist workshop

Environmental protection

Raw material recovery instead of waste disposal!

To avoid transport damage, the device must be shipped in sturdy packaging. Packaging as well as device and accessories are made of recyclable materials.

The plastic parts of the device are marked according to the material. This enables environmentally compatible, single-variety disposal via the collection facilities offered.

For EU countries only

Do not dispose of power tools in household waste! According to the European Directive 2012/19/EU on waste electrical and electronic equipment and its implementation in national law, used power tools must be collected separately and recycled in an environmentally friendly manner.

Noise / Vibration

The noise of this power tool is measured according to DIN 45 635, part 21. The sound pressure level at the workplace can exceed 85dB (A); in this case, sound protection measures for the operator are required.

Wear hearing protection!



Hand/arm vibration is typically lower than 2.5m/s². Measured values determined according to EN 61 029.

The specified vibration level represents the actual applications of the power tool. However, if the power tool is used for other applications, with deviating application tools or insufficient maintenance, the vibration level may deviate. This can significantly increase the vibration load over the entire working period.

For an accurate estimation of the vibration load, the times should also be taken into account when the unit is switched off or running but not actually in use. This can significantly reduce the vibration exposure over the entire working period.

Specify additional safety measures to protect the operator from the effects of vibration, such as: Maintenance of power tool and insert tools, keeping hands warm, organization of work procedures.

Warranty

In accordance with our general terms and conditions of delivery, a warranty period for material defects of 12 months applies in business transactions with companies (proof by invoice or delivery bill). Damage caused by natural wear and tear, overloading or improper handling shall remain excluded from this. Damage caused by material or manufacturer defects will be remedied free of charge by repair or replacement. Complaints can only be accepted if the unit is sent to the supplier unassembled. Wear parts, such as rotor-stator, printed circuit board, bearings, water seals, oil seals, etc. are not covered.

Exploded view

DKB-200/3SH

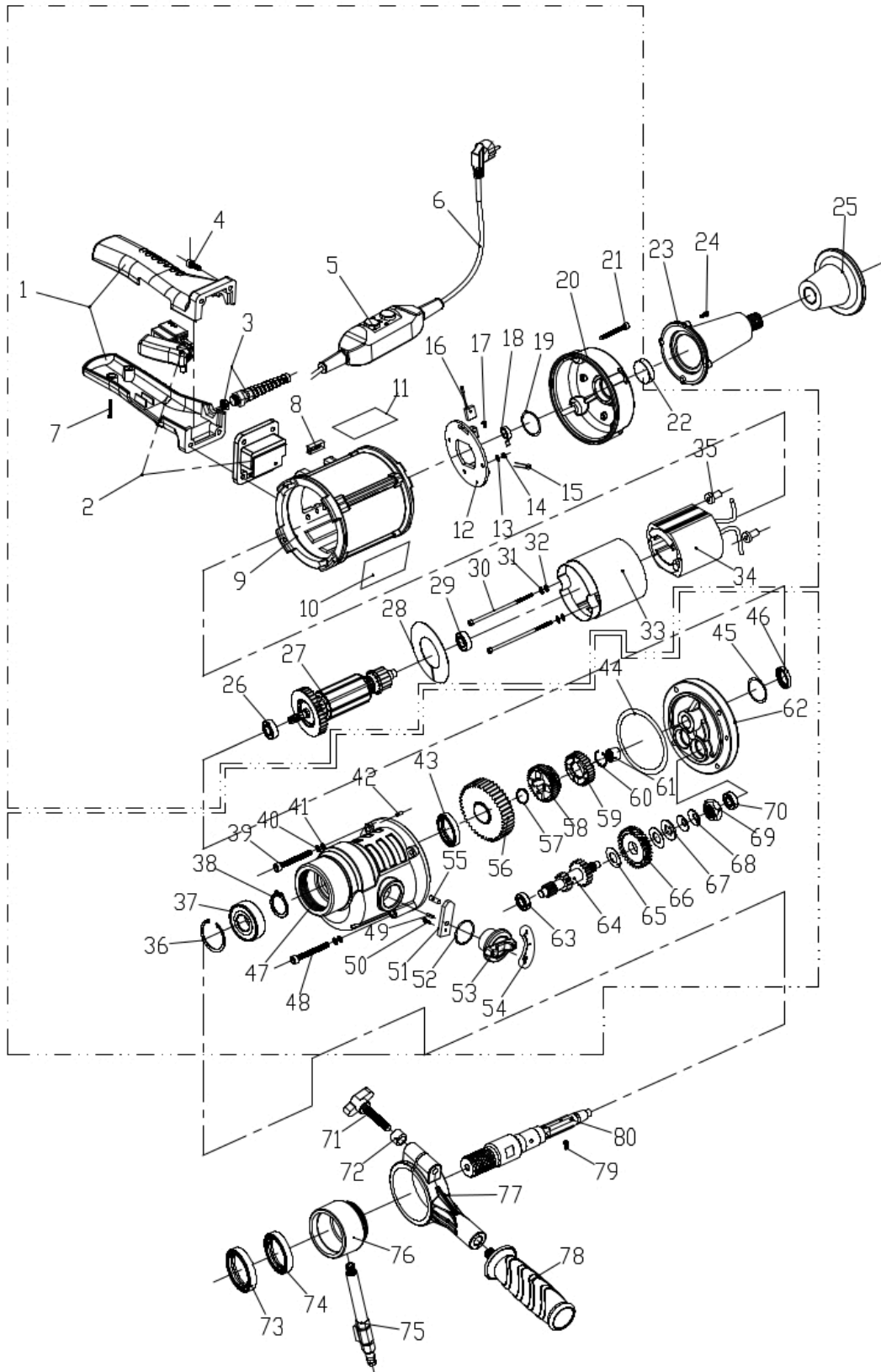

No.	Designation		Quantity	No.	Designation		Quantity
1	Main handle		1	41	Washer	M5	4
2	Speed regulation		2	42	Round key	4*12	1
3	Anti-bending sleeve	M12*1.5	1	43	Oil seal	22*35*7	1
4	Hexagon socket screws	M5*30	4	44	O-Ring	Ø85*1.8	1
5	PRCD		1	45	O-Ring	Ø28*1.8	1
6	Power cable	3*1.0*3.5m	1	46	Oil seal	12*24*7	1
7	Round head Phillips screws	M4*20	2	47	Gearbox		1
8	Spirit level	10*10*29	1	48	Hexagon socket screws	M5*70	2
9	Stator housing		1	49	Round key	3*14	1
10	Parameter plate	40*50	1	50	Hexagon socket screws	M5*10	1
11	Nameplate	60.3*29.5	1	51	Gear shift piece		1
12	Brush holder		1	52	O-Ring	Ø20*3	1
13	Washer	M4	2	53	Gear knob		1
14	Mother	M4	2	54	Switch plate		1
15	Capacity		2	55	Round key	5*15	1
16	Carbon brush		2	56	Gearbox		1
17	Phillips screw with round head	M3*6	2	57	Circlip		1
18	Spring		2	58	Gearbox		1
19	O-Ring	Ø25.8*1.8	1	59	Gear		1
20	Top cover		1	60	Inner circle		1
21	Hexagon socket screws	M5*40	4	61	Ball bearing		1
22	Spirit level	15*6	1	62	Medium cover		1
23	Shoulder holder		1	63	Bearing	629	1
24	Hexagon socket screws	M4*16	4	64	Grade I gear shaft		1
25	Plastic shoulder holder		1	65	Clutch seal	12.2*27.8*1	2
26	Bearing	6001	1	66	Grade I gear		1
27	Rotor		1	67	Clutch washer		1
28	Baffle plate		1	68	Friction disk	12.1*27.8	1
29	Bearing	6000	1	69	Mother	M12*1.0-6	1
30	Hexagon socket screws	M4*100	2	70	Bearing	608	1
31	Spring washer	M4	2	71	Wing screw	M8*55	1

32	Washer	M4	2	72	Wheel	8*14*10	1
33	Socket		1	73	Oil seal	38*47*7	1
34	Stator		1	74	Oil seal	38*49*8	1
35	Insulating sleeve	Ø8*14.5	2	75	Faucet		1
36	Inner circles		1	76	Water ring		1
37	Bearing	6005	1	77	Clamp		1
38	Outer circlip		1	78	Auxiliary handle		1
39	Hexagon socket screws	M5*45	2	79	Ball screw	M8*15	1
40	Spring washer	M5	4	80	Spindle		1

EC Declaration of Conformity

The manufacturer/marketer
Kernlochbohrer GmbH
Geigersbühlweg 52
72663 Großbettlingen
hereby declares that the following product

Product name: Core drill
Type: DKB-132/2H; DKB-165/3SH; DKB-180/3H, DKB-200/3SH

complies with all relevant provisions of the applied legal regulations (hereinafter) - including their amendments in force at the time of the declaration. The sole responsibility for issuing this declaration of conformity lies with the manufacturer. This declaration refers only to the machine in the condition in which it was placed on the market; parts added and/or interventions made subsequently by the end user are not taken into account.

The following legislation has been applied:
Machinery Directive 2006/42/EG
EMC Directive 2014/30/EU
RoHS Directive 2011/65/EU

The protection goals of the following other legal regulations were met:
Low Voltage Directive 2014/35/EU

The following harmonized standards have been applied:

EN 60204-1:2006/AC:2010	Safety of machinery - Electrical equipment of machines - Part 1: General requirements (IEC 60204-1:2005 (Modified))
EN ISO 12100:2010	Safety of machinery - General principles for design - Risk assessment and risk reduction (ISO 12100:2010)
BS EN 62841-2-1	Electric motor-driven hand-held tools, portable tools, and lawn and garden machinery. Safety Special requirements for hand-held drills and impact drills.
EN 61000-6-1:2007	Electromagnetic compatibility (EMC) - Generic standards; Immunity for residential, commercial and light-industrial environments
BS EN 61000-6-3+A1	Electromagnetic compatibility (EMC). Basic technical standards. Interference emission for residential, commercial and small businesses.

Name and address of the person authorized to compile the technical documentation:

Kernlochbohrer GmbH
Geigersbühlweg 52
72663 Großbettlingen

Location: Großbettlingen
Date: 24.05.2023

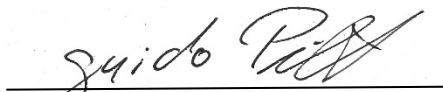

Guido Pillat, Chief Executive Officer